

# **Baffle tube set for GSO-RC telescope**

- **Installation instructions**
- **How it works**



## Contents

Scope of delivery.....	3
Installation .....	3
GSO RC telescopes 14" and 16": Differences between the versions, interfering light problem.....	3
Earlier version of the baffle tube .....	4
Earlier version of the baffle tube with diaphragm.....	5
Current version of the baffle tube .....	6
Design of the baffle tube set .....	7

### Scope of delivery

- Baffle tube with adapter
- Extension for secondary baffle tube

### Installation

Primary-side baffle tube: Unscrew the original baffle tube together with the adapter from the M117 external thread of the holder leading through the primary mirror and screw on the new baffle tube.

Secondary baffle tube extension: The upper end can be identified by the screws located close to the edge.

Slide the extension onto the secondary baffle tube until the upper end is level with the upper end of the smooth (i.e., non-ribbed) part of the original baffle tube and carefully tighten the six grub screws.



### GSO RC telescopes 14" and 16":

#### Differences between the versions, interfering light problem

Older versions of the telescopes were equipped with a large baffle tube (on the primary mirror side). After the problem of interfering light became known, many owners of these telescopes fitted the baffle tubes with a diaphragm reducing the diameter or an extension. This prevents interfering light from entering.

The negative effect of such a change is usually not taken into consideration: the aforementioned changes to the baffle tube cause a significant increase in vignetting. This can go so far that only the center of the image is free of vignetting. The newer, current versions of the telescopes have smaller-diameter baffle tubes. There are now no more problems with interfering light even with full-frame sensors.

However, the effects are logically the same as with the solution with the diaphragm or extension.

The baffle tube set eliminates the basic conceptual problem by using a large HS-side baffle tube together with an extension/enlargement of the secondary mirror baffle tube.

The modified design means that the field of view protected from interfering light is significantly larger than is required for a full-frame sensor. This means that even a 0.8x reducer can be used. The beam paths of the different variants are shown on the following pages.

The beam path is only ever shown for the right half of the telescope and only between the secondary mirror and the camera sensor, because otherwise the number of lines would be confusing.

The optical path on the optical axis and the path to the corner of an APS-C and a full-frame sensor as well as the interfering light path are shown.

### Earlier version of the baffle tube

Even if the interfering light only enters from one side, it already reaches more than the diagonal of an APS-C sensor; therefore, there is no area of the image field that is protected from interfering light.

- Line colors
- black, dashed: optical path on the optical axis
  - green: optical path to the corner of a full-frame sensor
  - blue: optical path to the corner of an APS-C sensor
  - red: possible interfering light path

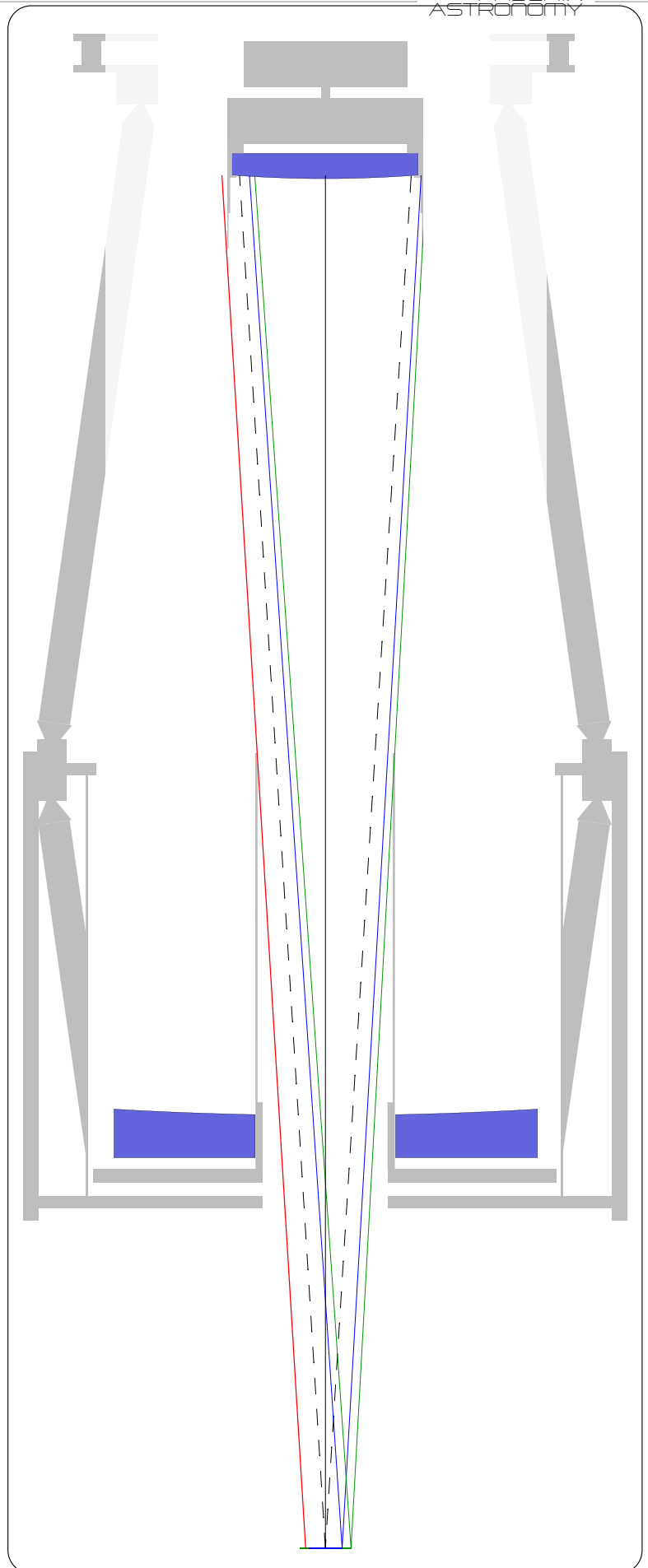

### Earlier version of the baffle tube with diaphragm

With an diaphragm (or baffle extension), the interfering light path is effectively blocked.

The unprotected area only begins outside the diagonal of a full-frame sensor.

At the same time, however, the outer area of the light path is heavily vignetted. It is easy to see that in the example shown, the optical path is only not vignetted on the optical axis.

#### Line colors

black, dashed:

optical path on the optical axis

green:

optical path to the corner  
of a full-frame sensor

blue:

optical path to the corner  
of an APS-C sensor

red:

possible interfering light path

orange: vignetting

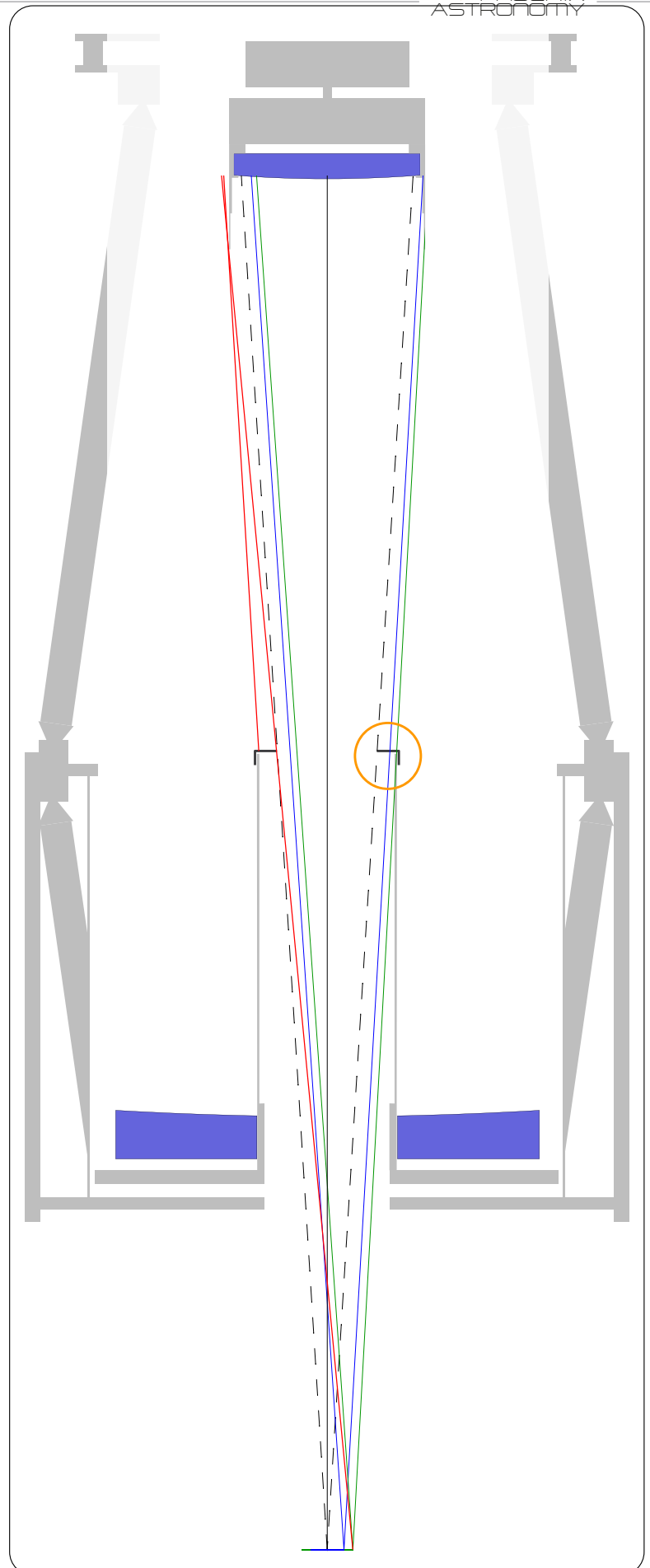

### Current version of the baffle tube

The smaller baffle tube currently used corresponds to the effects of the diaphragm shown on the previous page: The area of a full-frame sensor is protected, but the light path is heavily vignetted.

#### Line colors

black, dashed:  
optical path on the optical axis

green:  
optical path to the corner  
of a full-frame sensor

blue:  
optical path to the corner  
of an APS-C sensor

red:  
possible interfering light path

orange: vignetting

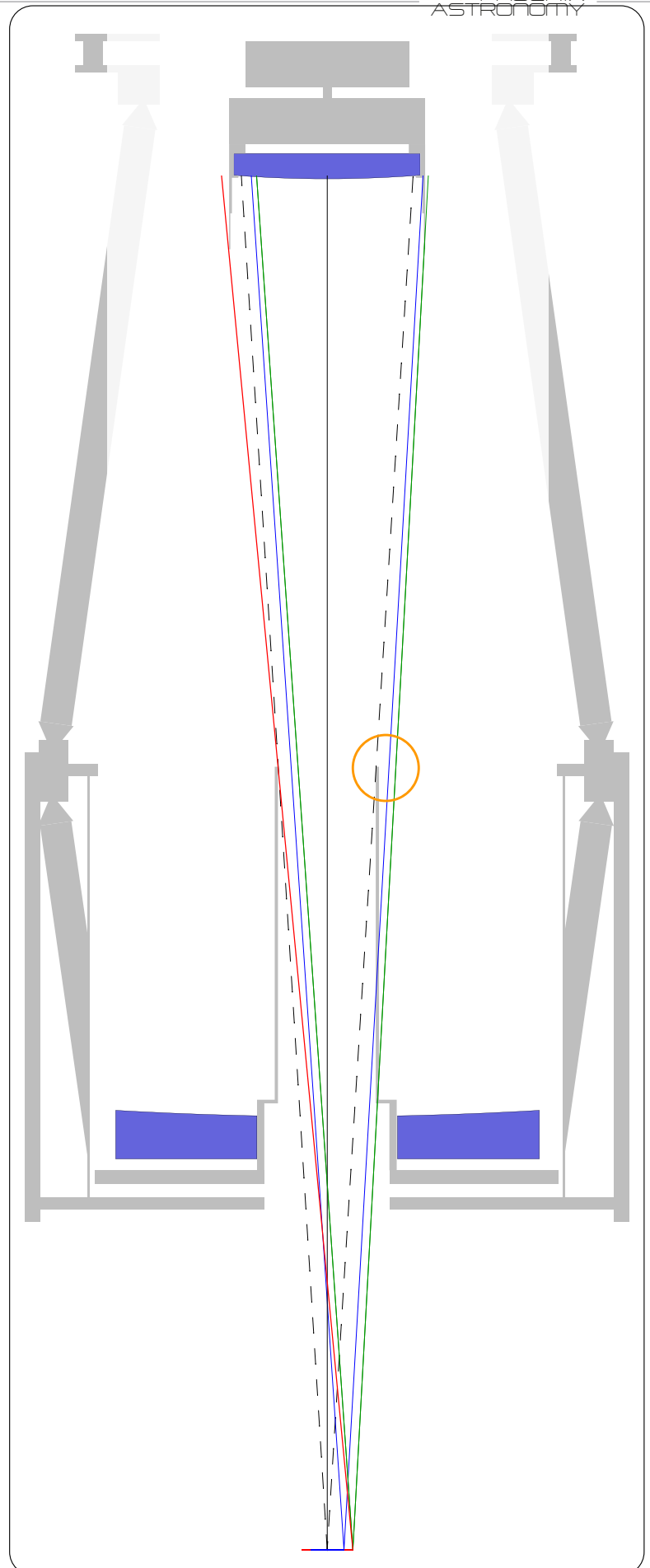

## Design of the baffle tube set

The baffle tube set is of such design that the protected field of view is large enough to be able to use a full-frame sensor with 0.8x reducer without any problems.

This is achieved with a generously dimensioned baffle tube on the primary mirror side in combination with an extension/enlargement of the secondary baffle tube.

The design of the standard secondary assembly causes slight vignetting with sensors in APS-C format and larger. This is not increased by the baffle tube set. The best possible illumination is therefore achieved.

The loss of light due to the slightly larger obstruction is minimal and amounts to approx. 3 % with the 16" telescope and approx. 6 % with the 14" version.

### Line colors

- purple:  
design of the baffle tube set
- black, dashed:  
optical path on the optical axis
- green:  
optical path to the corner  
of a full-frame sensor
- blue:  
optical path to the corner  
of an APS-C sensor
- red:  
possible interfering light path

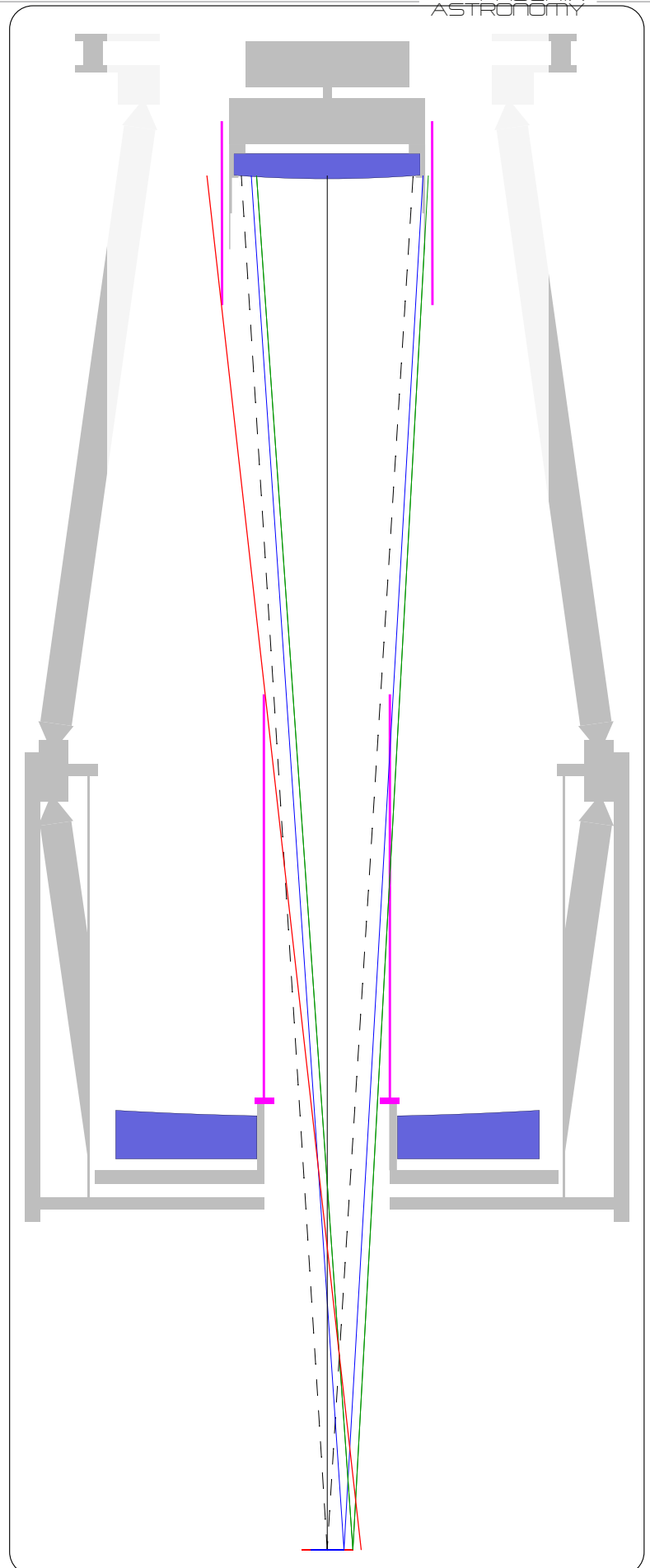

© © Copyright Phoenix Astronomy  
Subject to errors and changes.

Phoenix Astronomy  
Markus Schepp  
Schöne Aussicht 22  
D-61276 Weilrod